

"HEADLIGHT" BACK ISSUES

The following back issues are still available:

- 2nd/1979 Vol. IX No. 2
Observation Cars, G.&O.
- 3rd/1979 Vol. IX No. 3
Business Cars, Part III
- 4th/1979 Vol. IX No. 4
Xmas Eve, 1904; K.&M.; B/4 Tales
- 3rd/1980 Vol. X No. 3
N.Y.C. U.S.R.A. Design Hopper Cars
- 4th/1980 Vol. X No. 4
"999", Car 61, Ginger Hill Wrecks
- 1st/1981 Vol. XI No. 1
Steam Heat Trailers, B/4 Tales
- 2nd/1981 Vol. XI No. 2
K-11 Pacifics
- 3rd/1981 Vol. XI No. 3
N.Y.C. Streamlined Steam Locomotives
- 4th/1981 Vol. XI No. 4
Tug #34, Ives Steam Photos, G.&O.

The price of the above issues is \$2.00 per copy. Also available is the reprinted Niagara issue Aug. 1975 Vol. V No. 3: Niagara Road Testing. The price of this reprinted issue is \$2.50 per copy. Back issues are available to current members only. Please address your orders to the society at P.O. Box 10027, Cleveland, Ohio 44110, stating your member number on your order. If you need these issues, don't delay placing your order; our supplies won't last indefinitely, and future demand may not be sufficient to justify a reprint.



"You promised me you wouldn't eat garlic salami again!"

R. F. K.

HIGH SPEED WATER SCOOP AND LOCOMOTIVE TENDER DESIGN FOR THE NEW YORK CENTRAL SYSTEM

Carl F. Kantola
Assistant Engineer, Equipment Engineering Department

During the summer of 1943 railroad traffic was approaching the wartime peak and the 20th Century Limited and other fast trains were still the principal means of intercity passenger transportation. Mr. H. W. Faus, Engineer of Motive Power, received a complaint from President Williamson's office that passengers on some of our best trains were being suddenly awakened at night by a rush of water entering the screened windows of their Pullman berths. At the time, there were still many non air-conditioned cars in service.

Since I had a general idea of the source of the trouble, I was assigned to investigate the complaint and develop a solution. In order to demonstrate just what was taking place when water was scooped, a test train consisting of class J-1e Hudson #5328 with 14,000 gallon, 28 ton tender, dynamometer car X-8006, and two coaches was assembled. Mr. Fred Beach, our company photographer and myself were to ride on top of the tender tank with a movie camera directed at the water filling hole to record what happened while scooping water. The tests were run on the Rome, N.Y., track pans.

The test run turned out to be a very hazardous trip into a 20 mph head wind at 80 mph track speed. As we expected, the force of the water in the tank bent the filling hole cover at each side of the centrally-located latch. The water rushed out, flooding the tank top and cascading over both sides and the rear of the tender. Although we were thoroughly drenched and were nearly washed overboard, we managed to hang on and to also save the movie camera.

The movies, when later shown in the president's office, clearly illustrated how the people on passing trains had been showered. They also gave an understanding as to how other incidents had occurred. One was the case of a man's torso, arms and legs missing, which had been found in a tender tank. Apparently he had been riding on a tender, had been washed overboard onto an adjacent track pan, and had then been scooped up by another train. Another case was that of a transient who stole a ride on the rear of a tender in the winter time, and who was later found frozen to the handrails after having been wet by the overflow while scooping water.

After the session in the president's office the not-unexpected question was "What can we do about it?" Anticipating the question, I had a set of marked-up prints ready. Mr. Faus agreed with my proposals, so we proceeded with the design of a new water scoop and a new interior tender tank design. As the old saying goes, "Necessity is the mother of invention."

The existing design of scoop and tender had not been improved as tenders had become larger and higher operating speeds had become common. Maximum scooping speed was restricted to 45 mph. The scoop opening was undersize and the riser pipe into the tank had a reverse bend at its top towards the rear of the tender. This last caused a fast build-up of water at the rear of the tender, with very little supplied to the forward compartments of the tender tank. No air vents or overflow means were provided. The only escape for trapped air and overflowing water was through the



Carl Kantola with movie camera on tender platform preparing for a test run scooping water at 80 M.P.H.



Class S1a locomotive #6000, Niagara type, with 14-wheel PT tender. Tender equipped with high speed water scoop, auxiliary surge tank and six overflow vent pipes on each side. Carl F. Kantola

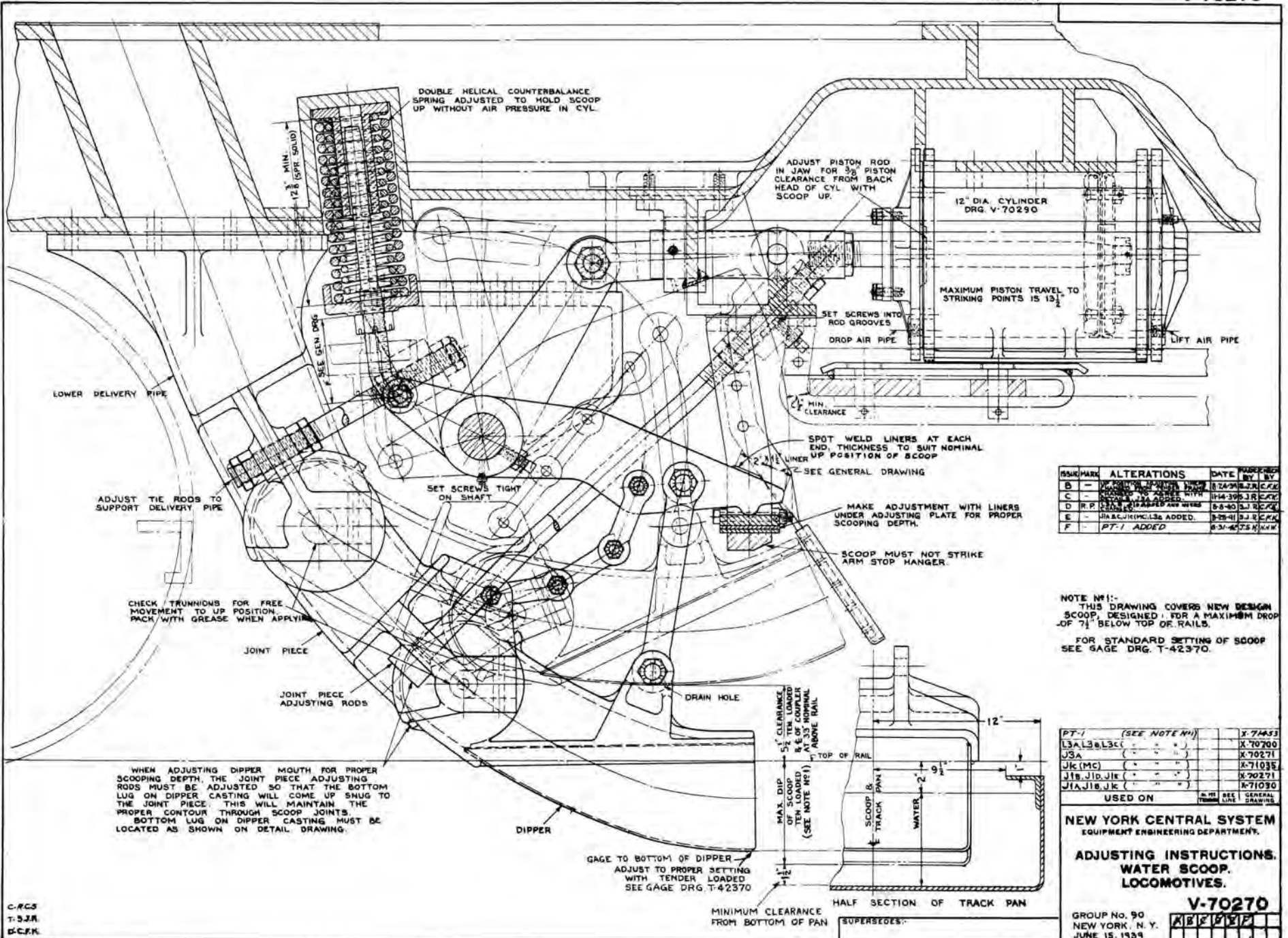

ISSUE/REV.	ALTERATIONS	DATE	BY	CHKD.
B	REVISIONS TO THIS DRAWING MADE	8-24-30	J.R.C.	J.R.C.
C	REVISIONS TO THIS DRAWING MADE WITH	11-4-30	J.R.C.	J.R.C.
D	REVISIONS TO THIS DRAWING MADE	8-8-40	J.R.C.	J.R.C.
E	REVISIONS TO THIS DRAWING MADE	8-28-41	J.R.C.	J.R.C.
F	PT-1 ADDED	8-31-47	J.R.C.	J.R.C.

NOTE #1:- THIS DRAWING COVERS NEW DESIGN SCOOP, DESIGNED FOR A MAXIMUM DROP OF 7 1/2" BELOW TOP OF RAILS.

FOR STANDARD SETTING OF SCOOP SEE GAGE DRG. T-42370.

PT-1	(SEE NOTE #1)	X-70453
L3A, L3B, L3C		X-70700
J3A		X-70271
J4C (MC)		X-71035
J1B, J1D, J1E		X-70271
J1A, J1B, J1C		X-71030

USED ON

NEW YORK CENTRAL SYSTEM
EQUIPMENT ENGINEERING DEPARTMENT.

ADJUSTING INSTRUCTIONS. WATER SCOOP. LOCOMOTIVES.

V-70270

GROUP No. 90
NEW YORK, N. Y.
JUNE 15, 1939

APPROVED	DATE

C.R.C.
T.S.J.R.
B.C.F.K.



This is a close-up of a locomotive PT tender scooping water. This tender is equipped with overflow control and excess water is discharged from four of the forward end overflow-vent pipes each side, indicating that interior construction of tender permits scooped water to be carried to the extreme forward end of tender instead of cresting in the rear portion of tender. Note the paved gutters between tracks onto which the overflow water is directed so that no damage is caused by same. 6,000 gallons in 17 seconds creating the effect of jet propulsion, speed 85 M.P.H.

filling hole. The end result was a partially filled tank and sometimes a heavy overflow which would bend the filling hole cover on either side of the latch and which would be discharged over the sides and rear of the tender. It was such overflows that damaged windows of passenger trains on adjacent tracks, and the head car of the train behind the tender. This overflow also caused damage to the track ballast and to journal boxes. Under these conditions, this scoop spilled more water than it delivered to the tender.

Having experienced the above conditions firsthand, I proceeded to design a new high speed water scoop and tender with overflow control and proper venting. The new design scoop is best illustrated on drawing V-70270 which covers the adjusting instructions and illustrates the scoop both in the operating position and the raised position. Rather than having a sharp upward curve, this scoop forms a long sweeping parabolic curve upward to the bottom of the tender, thus allowing the water from the pan to flow more freely into the tank. The mouth of the scoop has a large opening 14" wide by 8" high. Though the normal scoop is set for 6½" below top of rail, the larger opening allows the crest of water in the track pan to enter the mouth of the scoop. The

bottom portion of the scoop which enters the water is made of 3/16" steel plate rather than a heavy casting, so that it will cut the water more efficiently. This also provides a safety feature, for in the event that the bottom of the scoop hits an obstruction it can tear off without damaging the scoop castings. Scoop setting is adjustable by means of liners in the down position hanger, under the rocker arm. The opposite end of the rocker arm is attached to a double coil spring, which is compressed when air pressure is applied to the actuating cylinder for the down position and holds the scoop in up position after it is raised by air pressure in the cylinder. The water scoop operating valve is located at the front of the tender on the left side for the fireman to operate. Also at this location are try cocks which can be opened to indicate water level in the tank. See sketch and instructions dated December 15, 1943.

It was found during tests that some time was lost in operating the scoop due to the distance between the operating valve and cylinder on the larger tenders. Therefore an electro-pneumatic quick-acting valve was located near the cylinder and operated by a push button in the locomotive cab. Purple lights on standards located 75 feet in from each end of the track pans indicated when to lower and raise the scoop.

The drawing dated June 25, 1943 clearly illustrates the features of a tender tank equipped with overflow control. The water scoop delivery pipe inside the tank extends above the water line of a full tender so as not to drain water downward. The upper end of this pipe is turned forward to force the flow of water to the front of the tank. A divider is located directly ahead of the pipe to divert the flow to the compartments on each side of the coal space. Four vent pipes are located at the top of each side compartment to allow escape of trapped air and for overflow of water when the tender is filled. These pipes with a reverse bend extend downward below the tank and are directed to drain onto the paved gutter. Syphon breakers are provided at the reverse bends to prevent loss of water through syphoning action. Two expansion reservoirs are constructed to the rear of the coal space on top of the tank. The surge of water while scooping rises up into these reservoirs and then levels off the water supply after the scoop is lifted. Two air vent and overflow pipes are provided on each side of these tanks. Two additional air vent and overflow pipes are also provided, one at each corner of the rear tank top. A trap door hinged to the bottom edge of the filling hole funnel is provided to act as a check valve. A counter-weighted arm on this door holds it in the closed position, thus providing a seal against overflow through the filling hole cover. When taking water from an overhead spout in the conventional manner, the weight of water on this trap door will open it.

Water scoops were not new devices, having been in use on the New York Central since 1870, and 11 years earlier in England. However, the new design of this high speed 80 mph water scoop and the interior design of the tender tank with air venting and overflow control consisted of so many new and novel features that three U.S. patents, nos. 2,438,397, 2,534,452 and 2,534,453 were granted. It took a few trips to the patent office to explain the operation of the high speed scoop to the patent examiners.

Tests of both the old and new design scoops were conducted on the Rome, N.Y. 2,000 foot track pans. The test train again consisted of class J1e Hudson #5328 with the same consist as was mentioned previously. H. W. Faus was in overall charge of the tests and Ted Fredriks and Mal Reigel were in charge of the dynamometer car. Fred Beach, with movie camera, and Carl Kantola rode the tender tank during these tests. Several test runs were made to the satisfaction of all concerned which clearly demonstrated the efficiency and operational safety of the high speed water scoop and tender design at speeds of up to 85 mph. As an indication of the force of water entering the tank, the speedometer in the dynamometer car showed a speed drop of 3 mph when the scoop was lowered into the track pan. The accompanying tabulation shows the comparative efficiency of the old and new water scoop designs. A second tabulation shows the results of water scooping in regular service with class S1b locomotive #6005 and a PT tender of 18,000 gallon capacity.



This is a close-up of a locomotive tender scooping water. This tender is equipped with overflow control and excess water is discharging from overflow vent pipes throughout the length of tender except the pipe which vents from the top portion of expansion chamber, indicating that the tender has filled with water but has not yet surged up to the highest part of the expansion chamber. Note the absence of any overflow from top.



N.Y.C. Hudson 5410 takes on water Westbound at the Corvna, Indiana track pans in 1946. Note working overflow vents on the PT tank. — Bob Lorenz Collection

The class L4b Mohawk freight locomotives were being built at the Lima Locomotive Works at the time of the tests, and were the first new locomotives to be built with the improved water scoop and tender design. The J1, J3, L3 and L4a classes were converted to the new design as they were shopped for heavy repairs.

It would have been a slow process to stop at an overhead water spout whenever water was required, or to cut off an engine for coaling. Therefore one can see why it was necessary to have main line coaling stations, such as at Wayneport, N.Y. and Elyria, Ohio, along with the track water pans to maintain long through runs of steam locomotives and schedules as fast as 16 hours between New York and Chicago.

With the advent of the diesel-electric locomotive, the track pans and coaling stations which served the steam locomotives are long gone, but it would be of interest to recall where they were located. Drawing SK-M-2547 shows these locations on the New York Central and drawing Sk-M-2548 shows these locations on the Michigan Central. There were 19 track pan locations on the N.Y.C., and 10 on the M.C. Each of these locations required a wayside power plant with pumps to refill the pans after each scooping and to provide steam heat to prevent freezing of the pans in the winter.

An accompanying sketch shows the cross section of the standard New York Central track pan. These dimensions were adopted after exhaustive tests in 1928 which were conducted under



Looking west towards end of Lydick, Indiana track pans, Track #1, November 20, 1945. Purple indicator light for end of pan at right. NYCSHS



Looking east at Lydick, Indiana track pans, Track #1, November 20, 1945. Note the guard rail at the end of pan. NYCSHS



The first Hudson, J1a #5200, at Cheektowaga, N.Y. on February 3, 1952. Note that tender has had auxiliary surge tank applied, to rear of coal space. Photo by Joseph Brauner, C.M. Smith collection



N.Y.C. J-1b 5212 at Tivoli, N.Y. approaching the track pans on August 30, 1941 with a Westbound extra train. Track pan shows up well in foreground. Edward L. May Collection



Rear view of tender, showing construction of the auxiliary surge tank back of the coal space. The "Dewitt Clinton" 1831 loco & tender on other track.

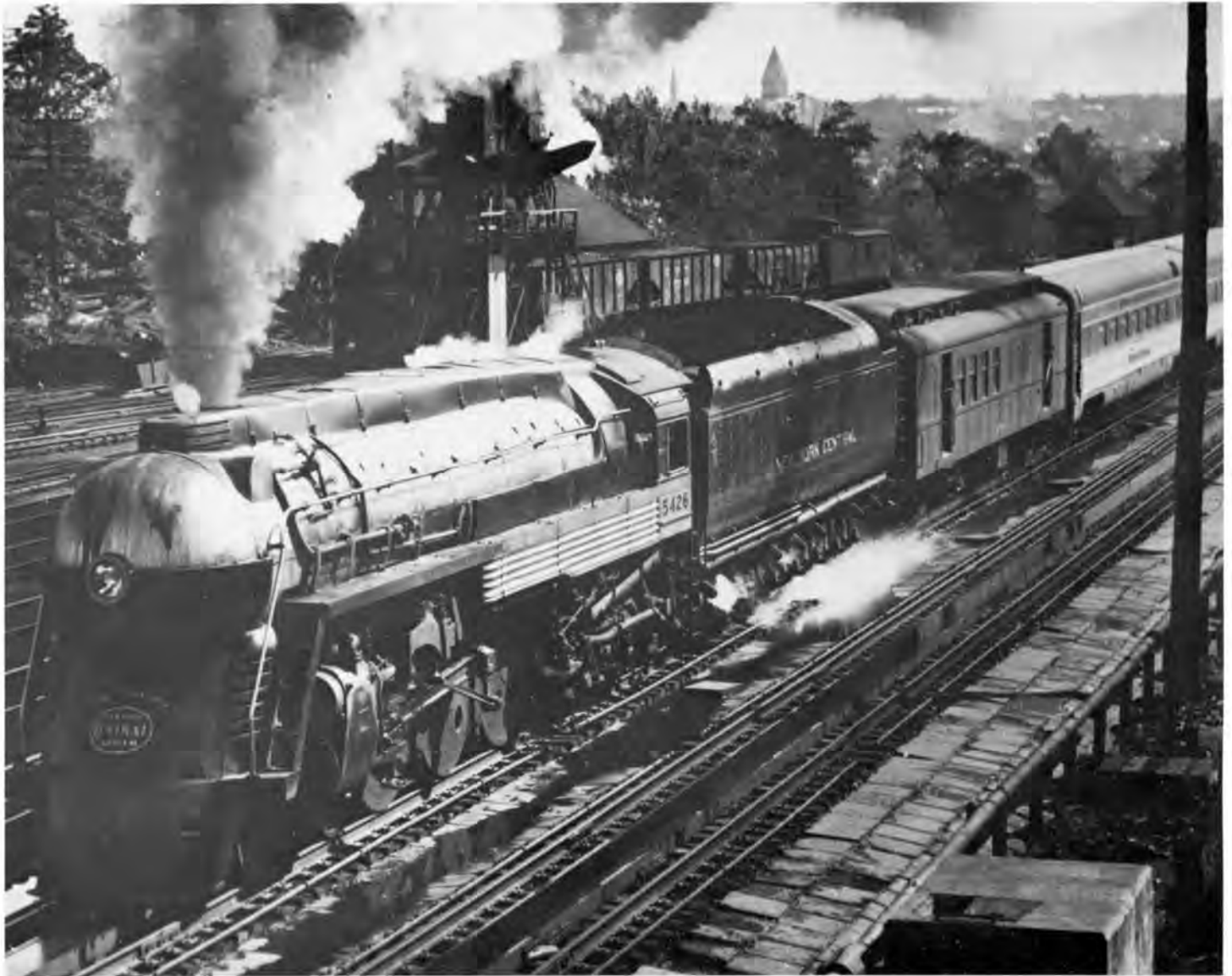

N.Y.C. 5426 with part of her streamline shrouding removed fills her PT-14 tender near Rennselear, N.Y. in 1947. Note track pan detail in near side track. Photo by Arnold Haas

the direction of John V. Neubert, Chief Engineer Maintenance of Way. At that time there were a number of different track pan designs in use, and tests were made on the pans at Rome, N.Y., Marshall, Mich., and Painesville, Ohio to determine the optimum dimensions.

The Rome pans consisted of two 8-in. channel sections, facing each other, riveted to a flat plate forming the bottom with a 20-in. opening and 8-in. depth. Top of pan was 1-9/16-in. below top of rail and water level was maintained 1/2-in. below top of pan.

The Painesville pans were of the bent plate type with continuous angle at the bottom for support along the outside edge and a 1 1/2-in. continuous angle along the outside at the top, with 18 7/8-in. opening and 7-7/16-in. depth. Top of pan was level with top of rail with water line maintained 1-in. below top of pan.

The Marshall pans were also a bent plate type with the supporting angle along the bottom but the 1 1/2-in. continuous angle at the top was on the inside with a 19-in. opening and top of pan 1 3/4-in. below top of rail with water level 3/4-in. below top of pan.

At the conclusion of these tests the following recommendations were made which were subsequently adopted as standard practice.

1. That the top of track pans shall be 1-in. below top of rail.

2. That the water in the track pans shall be maintained 1-in. below top of pan, or 2-in. below top of rail.

3. That the setting of the scoop shall be a maximum of 6-in. and a minimum of 5 1/2-in. below top of rail, which should make a 4-in. immersion in the water as a maximum.

4. That the speed restriction over track pans shall be 50 miles per hour.

5. That all future pans will be 8-in. deep with an opening of 19-in. at the top with angle turned in or towards the center of pan.

From the memories and collection of Carl F. Kantola, who is now 80 years old and retired since 1968. Mr. Kantola and his wife, Helen, reside at 576 Jamaica Boulevard HCAB, Toms River, N.J. 08757.

SELECTED BIBLIOGRAPHY WATER SCOOPS AND TRACK PANS

N.Y.C. Locomotives Scoop Water Without Reducing Speed; Railway Age, July 22, 1944, p. 149.

Design and Maintenance of Track Pans for Locomotive Water Supply; W. L. Curtiss, N.Y.C.R.R., Proceedings, American Railway Engineering Association, Vol. 36, 1935, p. 140.



N.Y.C. Niagara 6020 with train No. 43 scoops water from the Silver Creek, N.Y. track pans on a rainy February day in 1949. Much testing and design work went into equipment to make this operation possible. Photo by H. L. Vail Jr.



Before vents were installed, pressure built up and cracked the side of tender while testing the new design scoop.

Report on the Design and Maintenance of Track Pans for Locomotive Supply; W. B. McCaleb, PRR, Proceedings, American Railway Engineering Association, Vol. 30, 1929, p. 173.

Track Tanks; George W. Vaughan, N.Y.C. & H.R.R.R., Proceedings, American Railway Engineering Association, Vol. 14, 1913, p. 892.

Water Stations for Track Pans; E. G. Lane, Proceedings, American Railway Engineering Association, Vol. 12, 1911, p. 356.

Description of "One Pipe Circulation Method" Track Pans As Installed by the Lake Shore & Michigan Southern Ry. Co. at Painesville, Ohio; H. H. Ross, L.S. & M.S., Proceedings, American Railway Engineering Association, Vol. 12, 1911, p. 373.

Historical Notes on Water Supply on the New York Central & Hudson River R.R.; C. H. Rice, Bulletin 100, June 1908, American Railway Engineering and Maintenance of Way Association.

Railroad Track Tanks; H. H. Ross, L.S. & M.S., The Railroad Gazette, March 13, 1908, p. 337.

Modern Water Supply Stations for Locomotives; F. M. Whyte, American Railway Master Mechanics Association Proceedings, 1902, p. 287. (Abstracted in The Railroad Gazette, July 11, 1902)

Experiments with Scoops; American Engineering and Railroad Journal, July 1900, p. 211; November 1900, p. 344; December 1901, p. 376 and p. 392.

Design of N.Y.C. & H.R.R.R. Scoop; American Engineering and Railroad Journal, May 1901, p. 143.

Design of L.S. & M.S. Scoop; American Engineering and Railroad Journal; November 1900, p. 344; December 1901, p. 376.

Design of Kiesel Balanced Scoop, Used by PRR; American Engineering and Railroad Journal; November 1896, p. 283; The Railroad Gazette, January 8, 1897.

LIST OF PARTS (New)

- 31 Vent - overflow pipes from front tank cistern
- 32 Vent - overflow pipes from tank side compartments
- 33 Vent - overflow pipes from tank side compartments
- 34 Vent - overflow pipes from tank side compartments
- 35 Vent - overflow pipes from expansion reservoir
- 36 Vent - overflow pipes from expansion reservoir
- 37 Vent overflow pipes from rear tank top
- 38 Vent overflow pipe outlets or deflecting elbows
- 39 Vent overflow pipes syphon breakers with shields
- 40 Expansion reservoir
- 41 Openings thru tank top for water flow to reservoir
- 42 Openings thru rear vertical plate for water flow to reservoir
- 43 Small drain holes inside reservoir thru tank top for return flow
- 44 Manhole plate for expansion reservoir
- 45 High coping with turned in top edge around rear tank top
- 46 Filling hole funnel tapering to a small bottom opening
- 47 Trap door for bottom opening of filling hole funnel
- 48 Arm and weight to hold trap door in closed position
- 49 Trap door hinges
- 50 Water scoop delivery pipe extension or nozzle

- 51 Water flow divider
- 52 Water flow openings in bulkheads
- 53 Deflecting plate
- 54 Deflecting angle irons
- 55 Vertical solid plates with vent opening at high point
- 56 Vent openings at high point of plates
- 57 Tank full, try cock indicator at tank top
- 58 Tank overflowing, try cock indicating on overflow pipe
- 59 Ladder rungs in funnel pans.
- 60 Ladder below funnel

- 10 Front water tank top
- 11 Rear water tank top
- 12 Water bottom frame
- 13 Side water compartments
- 14 Top filling hole cover
- 15 Water lines from tender to locomotive
- 16 Tank top drains with plate deflector below
- 17 Water lines from tender to locomotive
- 18 Tender deck and cab apron plate
- 19 Water scoop operating valve
- 20 Tank cistern try cock indicators
- 21 Water scoop delivery pipe
- 22 Water scoop and operating rigging
- 23 Water pan between rails
- 24 Track rails
- 25 Track crossies
- 26 Paved gutter between ends of crossies
- 27 Tender truck frames
- 28 Tender truck wheels
- 29 Fuel space gates
- 30 Water space bulkheads

LIST OF PARTS (Original)

- 1 Rear of locomotive coupled to tender
- 2 Locomotive tender with water & fuel space
- 3 Fuel space of tender
- 4 Rear slope sheet of fuel space
- 5 Side slope sheets of fuel space
- 6 Bottom of fuel space
- 7 Stoker compartment
- 8 Stoker conveyor
- 9 Water space of tender

Arrows indicate general flow of water while scooping

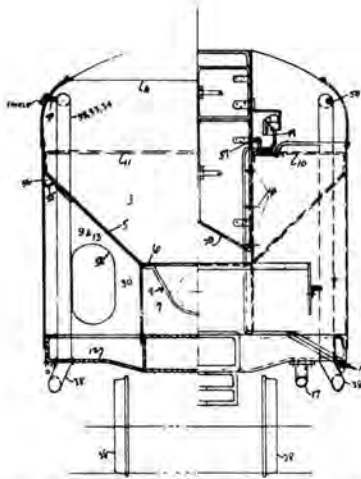

HALF SECTION Y-Y HALF FRONT END VIEW

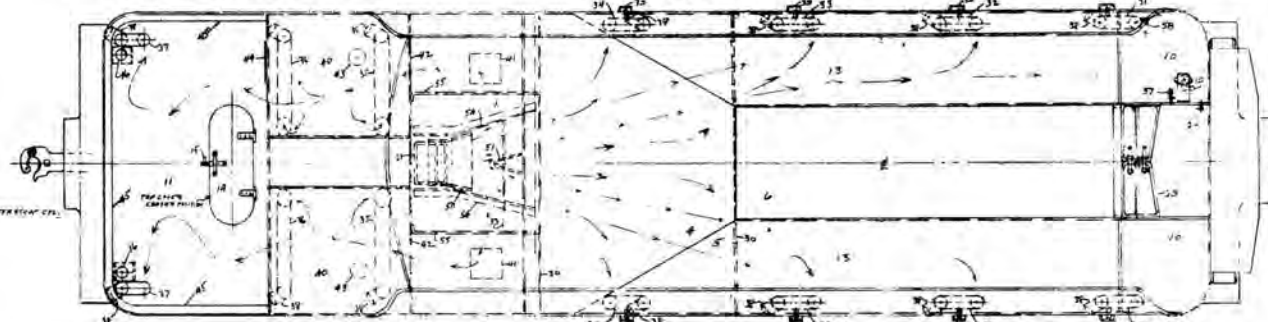

TOP PLAN VIEW

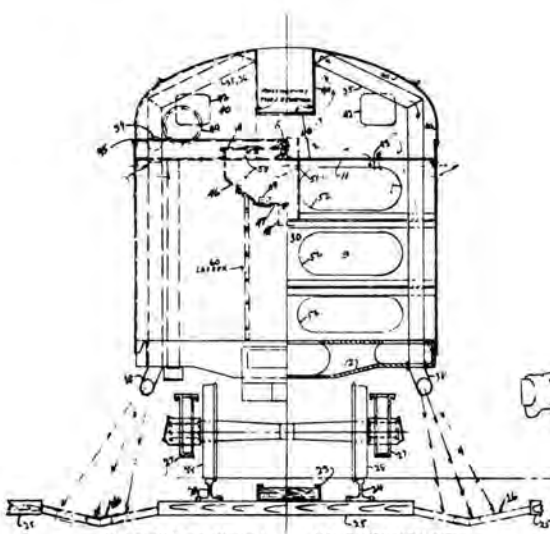

HALF REAR END VIEW HALF SECTION X-X

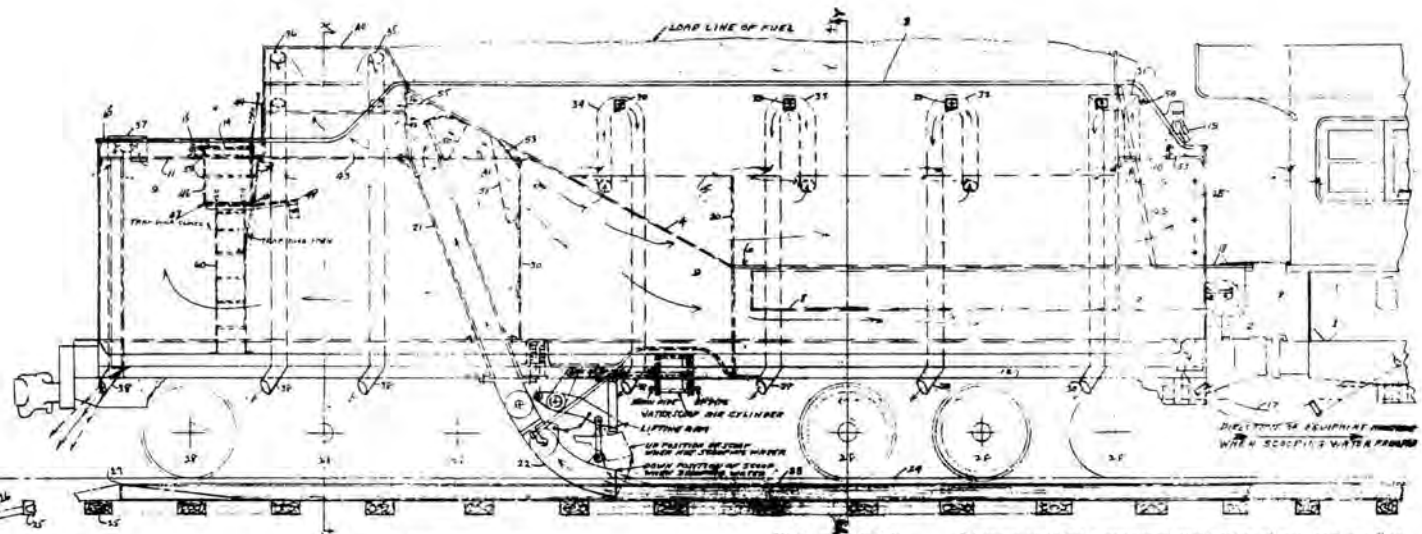

SIDE ELEVATION

TITLE: WATER SCOOPING OVERFLOW CONTROL DEVICES FOR LOCOMOTIVE TENDER TANKS

Drawing showing a proposed application of vent and overflow pipes, trycock indicators, expansion reservoir, filling hole funnel with trap door, raised coping on rear tank top, extension on waterscoop delivery pipe, and water flow divider in front of delivery pipe outlet, all onto locomotive tender for the purpose of controlling overflow etc. of water when scooping water from track pans. Designed by E. F. Kantola, Dumont, N.J. June 25, 1943.